

Tutorial on Modeling of Expansion Joints using CAEPIPE

The following examples illustrate the modeling of various types of expansion joints in CAEPIPE stress models.

Example 1: Tied Bellow (without gaps)

Whenever a bellow is present in a piping system, the equipment nozzle/piping support adjacent to the bellow will experience a pressure thrust force ($= \text{pressure thrust area} \times \text{pressure}$) generated by the bellow during normal operation. Tie rods can be added to the bellow in order to fully absorb such pressure thrust force, while still allowing the bellow to laterally deflect (i.e., allowing lateral displacement and lateral rotation).

In the example shown below, four tie rods are attached to the bellow without any “gaps” on tie rods on either side of the bellow. Because there are no “gaps”, the tie rods offer the same stiffness under both tension and compression (as long as the compression is not large enough to buckle the tie rods). In order to determine the axial force carried by each tie rod, pressure thrust area for the bellow must be input. One way of modeling the tie rods is to lump all four tie rods into a single tie rod along the bellow center line (with tension stiffness = compression stiffness = $n \times$ stiffness of each tie rod = $n \times EA/L$, where ‘n’ is the number of tie rods, E is the Young’s Modulus of the tie rod material, A and L are the cross-sectional area and length of each tie rod).

#	Node	Type	DX (ft/in)	DY (ft/in)	DZ (ft/in)	Mat	Sect	Load	Data
1	Title = Modeling of Tied Bellow								
2	10	From							Anchor
3	30					A53	8	L1	
4	40	Bellows		-2'0"		A53	8	L1	
5	50	Bend		-1'0"		A53	8	L1	
6	60		15'0"	-2'0"		A53	8	L1	Anchor
7	No. of Tie Rods = 4; Dia. of each Tie Rod = 3/4"; No gaps.								
8	30	From							
9	40	Tie rod							
10									

In the example shown above, the properties of the Tied Bellow are as follows.

Axial stiffness	2088	(lb/inch)
Bending stiffness	418	(in-lb/deg)
Torsional stiffness	1.000E+5	(in-lb/deg)
Lateral stiffness	34655	(lb/inch)
Pressure thrust area	71.82	(in ²)
Weight	2.11	(lb)
Mean diameter	0	(inch)

Note:

For Bending stiffness of the bellow, the following two options are provided.

Option 1: Input the Bending stiffness as specified by the manufacturer or as reasonably determined from industry standards such as EJMA. If a non-zero value for Bending stiffness is input, then leave the “Mean diameter” field blank.

Option 2: If a non-zero value for Bending stiffness is not input as per Option 1 above and is left blank, then input the actual non-zero value for “Mean diameter”, in which case CAEPIPE will internally calculate the Bending stiffness for the bellow based on the Mean diameter and other inputs provided for that bellow. In this case, the Mean diameter is the “mean” between the outer and inner diameters of any Convolution of the bellow. Since outer and inner diameters of all convolutions of the bellow are the same, the Mean diameter is the same for all convolutions of that bellow.

Among the above two options, Option 1 is recommended if you are able to specify a realistic non-zero value for the Bending stiffness of the bellow.

Tie Rods properties

No. of Tie Rods (n) = 4 Nos.

Diameter of Tie Rod (D) = 3/4”

Length of Tie Rod (L) = 12”

Young’s Modulus of Tie Rod (E) = 29.9E+6 psi

Stiffness of Tie Rods = $n \times AE/L = 4 \times (\pi/4) \times 0.75^2 \times 29.9E+6 / (12”) = 4.403E+6 \text{ lb/in}$

Accordingly, for Tie Rods, Tension Stiffness = Compression Stiffness = 4.403E+6 lb/in.

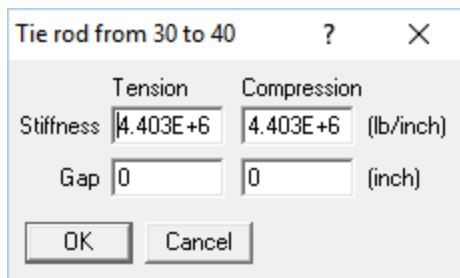
**Example 2: Tied bellow with free compression**

The model shown below has a tied bellow between Nodes 80 & 90. Tie Rod is defined with the same tension stiffness and compression stiffness of 6.848E+06 lb/in (equals to combined axial stiffness of 4 Nos. of 1.25” dia. tie rods). However, gaps are set differently in the tension and compression directions, namely 0.0” in the tension direction and 2.0” in the compression direction (assuming 2.0” as the maximum compression permitted by the manufacturer). This allows the bellow to compress freely up to 2.0” and at the same time restricts the bellow from extension. Beyond 2.0” of compression, compression stiffness of tie rods will come into play.

#	Node	Type	DX (ft/in)	DY (ft/in)	DZ (ft/in)	Matl	Sect	Load	Data
1	Title = 14" Steam Line								
2	Pressure = 175 psi; Operating Temp = 400 deg.F								
3	Pipe OD = 14" Sch 40; Cor.All = 0.03 in; Mill Tol = 12.5%								
4	10	From	4'0"		3'0"				Anchor
5	20		6'0"			A53	14	175	Flange
6	20	Location							Flange
7	30		8'0"			A53	14	175	Flange
8	30	Location							Flange
9	40		2'0"			A53	14	175	Limit stop
10	50		14'0"			A53	14	175	Flange
11	50	Location							Flange
12	60		2'0"			A53	14	175	
13	70		10'0"			A53	14	175	Guide
14	80		2'0"			A53	14	175	
15	90	Bellows	1'0"			A53	14	175	
16	(4) 1.25" Tie Rods to capture pressure thrust force								
17	Tie Rods modelled to allow compression while restricting Tension								
18	80	From							
19	90	Tie rod							
20	100		2'0"			A53	14	175	Anchor
21									

Bellows from 80 to 90

Axial stiffness: 1879 (lb/inch)

Bending stiffness: 803.47 (in-lb/deg)

Torsional stiffness: 7.036E+8 (in-lb/deg)

Lateral stiffness: 17942 (lb/inch)

Pressure thrust area: 126 (in²)

Weight: 308 (lb)

Mean diameter: 14 (inch)

OK Cancel

Tie rod from 80 to 90

Tension Compression

Stiffness: 6.848E+6 6.848E+6 (lb/inch)

Gap: 0 2 (inch)

OK Cancel

From “Flex. Joint” displacements results of CAEPIPE, it is observed that the deflection for bellow between Nodes 80 and 90 is +0.003” for Sustained Case and -1.359” for Expansion load case (which is less than the compression gap of 2.0” provided). Please observe that the bellow compresses for the Expansion load in this model as the bellow is in between two anchors. This confirms that the modeling of Tied bellow with 0.0” gap for tension and 2.0” gap for compression directions produces the expected results.

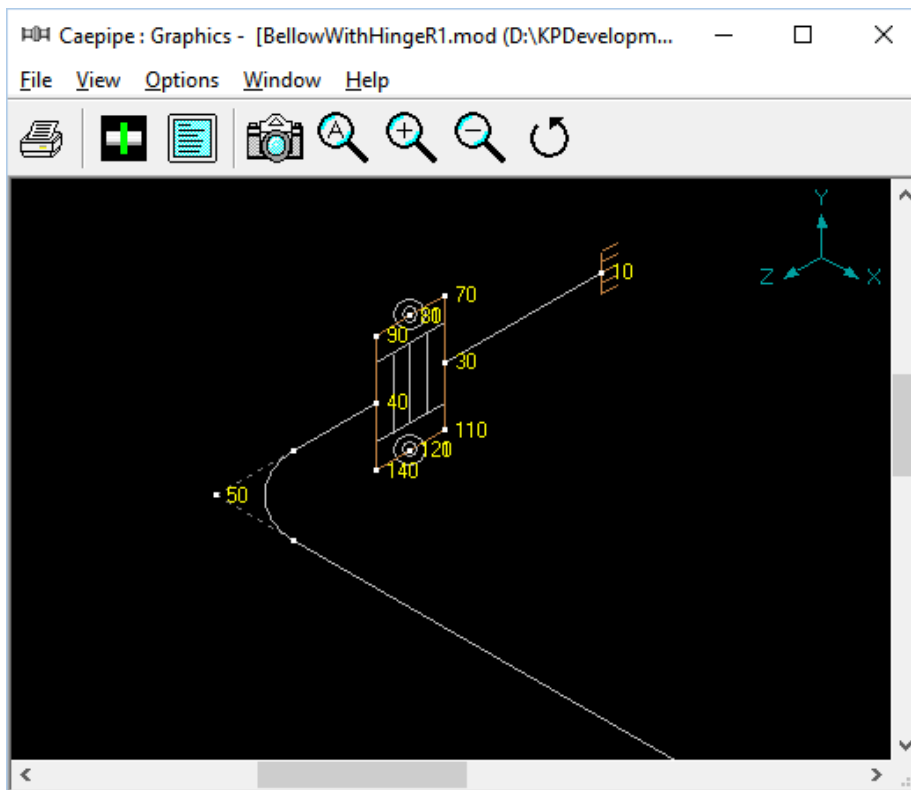
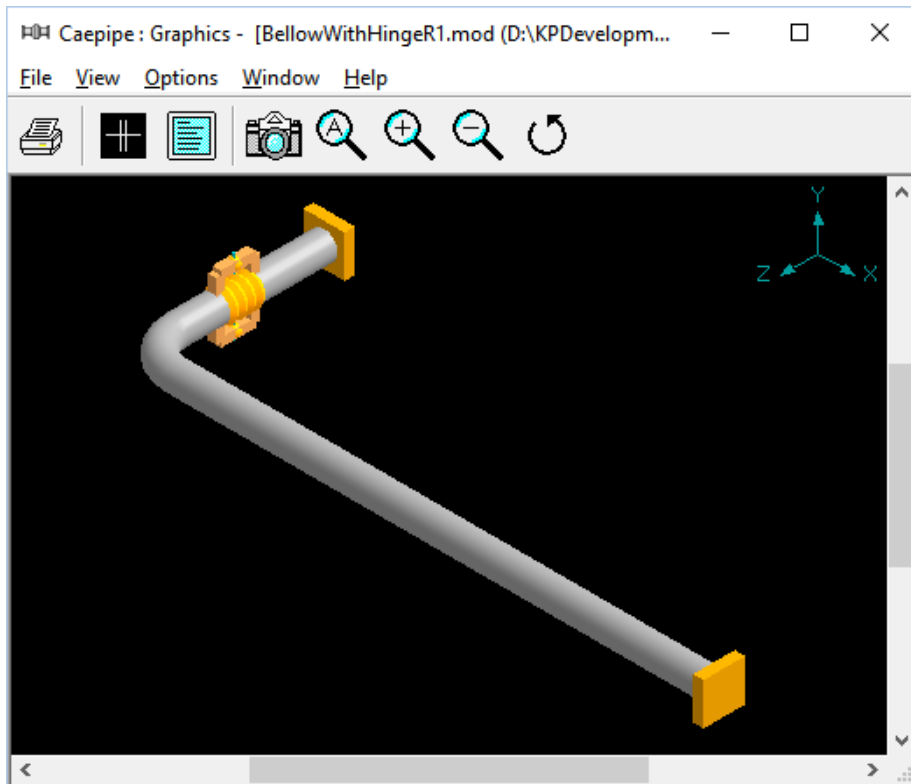

Caepipe : Pipe Sections (2) - [BellowWithHingeR1.mod (C...

File Edit View Options Misc Window Help

#	Name	Nom Dia	Sch	OD (inch)	Thk (inch)	Cor.Al (inch)	M.Tol (%)	Ins.Dens (lb/ft3)	Ins.Thk (inch)	Lin.Dens (lb/ft3)	Lin.Thk (inch)	Soil
1	B	8"	STD	8.625	0.322							
2	2	2"	STD	2.375	0.154							
3												

Caepipe : Loads (2) - [BellowWithHingeR1.mod (C:\Tutorials\05_BellowModeling\03_Hinged...

File Edit View Options Misc Window Help

#	Name	T1 (F)	P1 (psi)	Desg.T (F)	Desg.Pr. (psi)	Specific gravity	Add.Wgt. (lb/ft)	Wind Load 1	Wind Load 2	Wind Load 3	Wind Load 4
1	L0	70	0	70	0						
2	L1	500	200	500	200	0.1					
3											

Bellows from 30 to 40

Axial stiffness (lb/inch)

Bending stiffness (in-lb/deg)

Torsional stiffness (in-lb/deg)

Lateral stiffness (lb/inch)

Pressure thrust area (in²)

Weight (lb)

Mean diameter (inch)

OK Cancel

Hinge joint from 120 to 121

Rotational stiffness (in-lb/deg)

Rotation limit (deg)

Friction torque (ft-lb)

Weight (lb)

Axis direction

X comp	Y comp	Z comp
<input type="text"/>	<input type="text" value="1.000"/>	<input type="text"/>

OK Cancel

Now from the displacements results of CAEPIPE for Expansion load case, it is observed that the rotation at Node 40 is much larger than the rotation at Node 30 in YY direction. In other words, the hinges at Nodes 80 and 120 are allowing the two ends of the bellow to bend. This in effect confirms that the modeling of hinged bellow as shown in this model produces the expected results.

Caepipe : Displacements: Expansion (T1) - [BellowWithHingeR1.res (C:\Tutorials\BellowModeling\03_Hi...]

File Results View Options Window Help

#	Node	Displacements (global)					
		X (inch)	Y (inch)	Z (inch)	XX (deg)	YY (deg)	ZZ (deg)
1	10	0.000	0.000	0.000	0.0000	0.0000	0.0000
2	30	-0.034	0.000	0.075	0.0000	-0.1139	0.0000
3	40	-0.150	0.000	0.075	0.0000	-1.1176	0.0000
4	50A	-0.395	0.000	0.115	0.0000	-1.0776	0.0000
5	50B	-0.523	0.000	0.264	0.0000	-0.1753	0.0000
6	60	0.000	0.000	0.000	0.0000	0.0000	0.0000
7	70	-0.034	0.000	0.075	0.0000	-0.1139	0.0000
8	80	-0.045	0.000	0.075	0.0000	-0.1139	0.0000
9	81	-0.045	0.000	0.075	0.0000	-1.1176	0.0000
10	90	-0.150	0.000	0.075	0.0000	-1.1176	0.0000
11	110	-0.034	0.000	0.075	0.0000	-0.1139	0.0000
12	120	-0.045	0.000	0.075	0.0000	-0.1139	0.0000
13	121	-0.045	0.000	0.075	0.0000	-1.1176	0.0000
14	140	-0.150	0.000	0.075	0.0000	-1.1176	0.0000

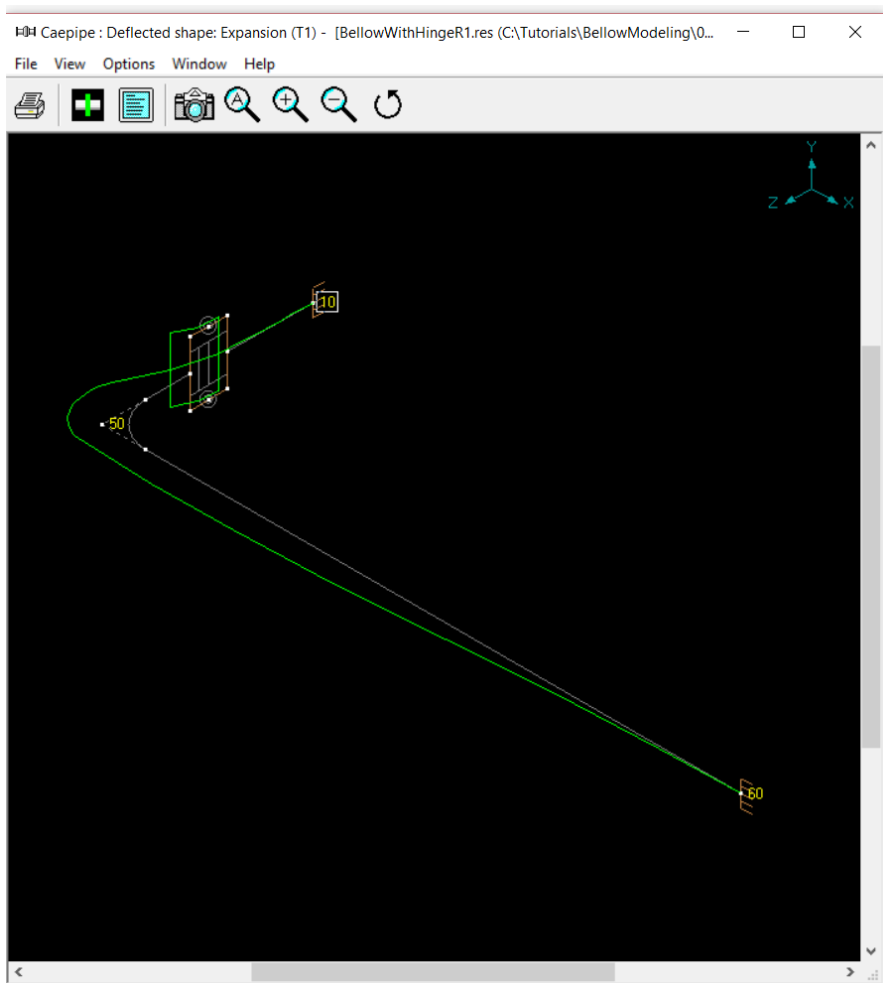

Example 4: Gimbal Bellow

A gimbal expansion joint is designed to permit angular rotation in any plane by the use of two pairs of hinges affixed to a common floating gimbal ring. The gimbal ring, hinges and pins are designed to restrain the thrust of the expansion joint due to internal pressure and extraneous forces, where applicable.

In this sample model, the Gimbal is simulated by connecting the Bellow Nodes 30 & 40 using two “massless” Rigid Elements and one Ball Joint (i.e., a Rigid Element from Nodes 30 to 70 followed by a Ball Joint connecting Nodes 70 & 80 and another Rigid Element from Nodes 80 to 40). All the stiffnesses of the Ball Joint are made as “Rigid” excepting the Bending Stiffness. The Bending Stiffness (the same applied in both “local y” and “local z” directions) is defined as “1” in-lb/deg. In addition, weight of this ball joint is left blank (i.e., equal to 0.0).

Caepipe : Layout (12) - [BellowWithGimbal_UsingBall.mod ...]

File Edit View Options Loads Misc Window Help

#	Node	Type	DX (ft'in")	DY (ft'in")	DZ (ft'in")	Matl	Sect	Load	Data
1	Title =								
2	10	From							Anchor
3	15	Bend			15'0"	A53	8	L1	
4	30			-2'0"		A53	8	L1	
5	40	Bellows		-0'10-3/4"		A53	8	L1	
6	Gimbal Assembly								
7	30	From							
8	70	Rigid		-0'5-3/8"		A53	2	L0	
9	80	Ball							
10	40	Rigid				A53	2	L0	
11	50	Bend		-2'0-5/8"		A53	8	L1	
12	60		15'0"			A53	8	L1	Anchor
13									

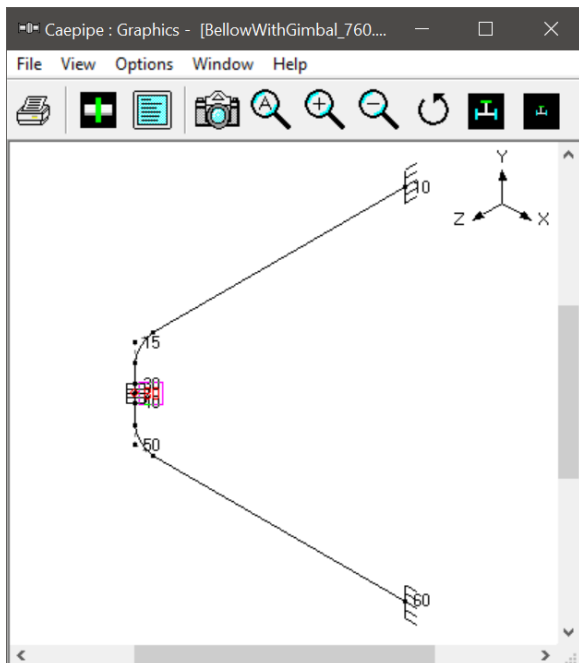

Caepipe : Pipe Sections (2) - [BellowWithGimbal_760.mo...]

File Edit View Options Misc Window Help

#	Name	Nom Dia	Sch	OD (inch)	Thk (inch)	Cor.Al (inch)	M.Tol (%)	Ins.Dens (lb/ft3)	Ins.Thk (inch)	Lin.Dens (lb/ft3)	Lin.Thk (inch)	Soil
1	B	8"	STD	8.625	0.322							
2	2	2"	STD	2.375	0.154							
3												

Caepipe : Loads (2) - [BellowWithGimbal_760.mod (C:\Tut...]

File Edit View Options Misc Window Help

#	Name	T1 (F)	P1 (psi)	Desg.T (F)	Desg.Pr. (psi)	Specific gravity	Add.Wgt. (lb/ft)	Wind Load
1	L0	70	0	70	0			
2	L1	500	200	500	200	0.1		
3								

Bellows from 30 to 40

Axial stiffness (lb/inch)

Bending stiffness (in-lb/deg)

Torsional stiffness (in-lb/deg)

Lateral stiffness (lb/inch)

Pressure thrust area (in²)

Weight (lb)

Mean diameter (inch)

Rigid element from 30 to 70

Weight (lb)

Add Content, Insulation and Lining weights (CIL)

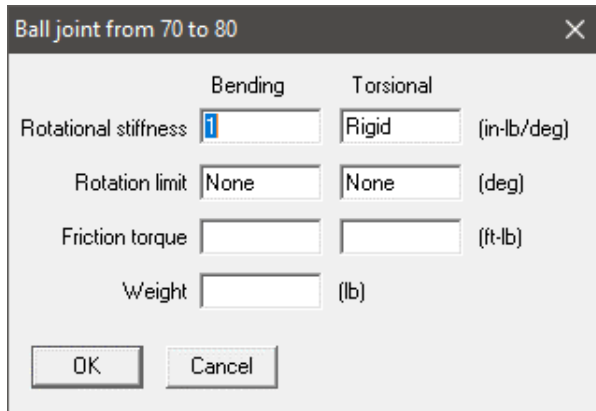

As expected, the “Displacements” results for the bellow displayed in CAEPIPE have a sudden change in XX and ZZ rotations, confirming the fact that the Gimbal is getting rotated in the two orthogonal directions due to the deformation of the two orthogonal lines.

#	Node	Displacements (global)					
		X (inch)	Y (inch)	Z (inch)	XX (deg)	YY (deg)	ZZ (deg)
1	10	0.000	0.000	0.000	0.0000	0.0000	0.0000
2	15A	-0.451	-0.093	0.530	0.0716	-0.1628	-0.1935
3	15B	-0.511	-0.153	0.539	0.1620	-0.0499	-0.1855
4	30	-0.551	-0.191	0.505	0.1658	-0.0197	-0.1896
5	40	-0.570	-0.191	0.473	0.1769	-0.0197	-0.0119
6	70	-0.569	-0.191	0.489	0.1658	-0.0197	-0.1896
7	80	-0.569	-0.191	0.489	0.1769	-0.0197	-0.0119
8	50A	-0.572	-0.231	0.434	0.1728	0.0120	-0.0074
9	50B	-0.530	-0.258	0.384	0.1836	0.1273	0.0914
10	60	0.000	0.000	0.000	0.0000	0.0000	0.0000

Example 5: Universal Hinged Expansion Joints

Universal Hinged Expansion Joints have two bellows separated by a pipe spool with overall length restrained by hinge hardware designed to contain pressure thrust. A hinged universal expansion joint accepts large lateral movements in a single plane with very low spring forces.

This sample model simulates the Universal Hinged Expansion Joints with two Tie Rods using the CAEPIPE's Tie Rod elements. The advantages of this model are (a) stiffness of the tie rods can be input explicitly (in this case, stiffness corresponding to 1" dia tie rod is input) and (b) gaps can be specified to simulate slotted holes.

In this sample model, the Universal Hinged Expansion Joint is simulated by connecting the Bellow Nodes 30 & 60 using Tie Rods and “massless” Rigid Elements, namely four “massless” Rigid Elements connecting Nodes 30-100, 30-220, 60-180 and 60-270; two Tie Rods connecting Nodes 100-180 and 220-270 and four hinges connecting Nodes 140-150, 160-170, 230-240 and 250-260. See snap shots shown below for details.

Bellows from 30 to 40

Axial stiffness (lb/inch)

Bending stiffness (in-lb/deg)

Torsional stiffness (in-lb/deg)

Lateral stiffness (lb/inch)

Pressure thrust area (in²)

Weight (lb)

Mean diameter (inch)

Bellows from 55 to 60

Axial stiffness (lb/inch)

Bending stiffness (in-lb/deg)

Torsional stiffness (in-lb/deg)

Lateral stiffness (lb/inch)

Pressure thrust area (in²)

Weight (lb)

Mean diameter (inch)

Hinge joint from 160 to 170

Rotational stiffness (in-lb/deg)

Rotation limit (deg)

Friction torque (ft-lb)

Weight (lb)

Axis direction

X comp	Y comp	Z comp
<input type="text"/>	<input type="text"/>	<input type="text" value="1.000"/>

Tie rod from 220 to 230

	Tension	Compression
Stiffness	<input type="text" value="2.500E+6"/>	<input type="text" value="2.500E+6"/> (lb/inch)
Gap	<input type="text" value="0"/>	<input type="text" value="0"/> (inch)

Caepipe : Displacements: Expansi...

File Results View Options Window Help

#	Node	Displacements (global)					
		X (inch)	Y (inch)	Z (inch)	XX (deg)	YY (deg)	ZZ (deg)
1	10	0.000	0.000	0.000	0.0000	0.0000	0.0000
2	20A	0.262	0.033	0.000	0.0000	0.0000	0.0178
3	20B	0.291	0.014	0.000	0.0000	0.0000	0.0185
4	30	0.294	0.000	0.000	0.0000	0.0000	0.0184
5	40	0.071	0.007	0.000	0.0000	0.0000	-0.9097
6	55	-0.071	-0.007	0.000	0.0000	0.0000	-0.9097
7	60	-0.294	0.000	0.000	0.0000	0.0000	0.0184
8	110A	-0.291	-0.014	0.000	0.0000	0.0000	0.0185
9	110B	-0.262	-0.033	0.000	0.0000	0.0000	0.0178
10	120	0.000	0.000	0.000	0.0000	0.0000	0.0000
11	100	0.294	0.000	0.000	0.0000	0.0000	0.0184
12	140	0.100	0.000	0.000	0.0000	0.0000	0.0184
13	150	0.100	0.000	0.000	0.0000	0.0000	0.0184
14	160	-0.098	0.000	0.000	0.0000	0.0000	0.0184
15	170	-0.098	0.000	0.000	0.0000	0.0000	0.0184
16	180	-0.294	0.000	0.000	0.0000	0.0000	0.0184
17	220	0.294	0.000	0.000	0.0000	0.0000	0.0184

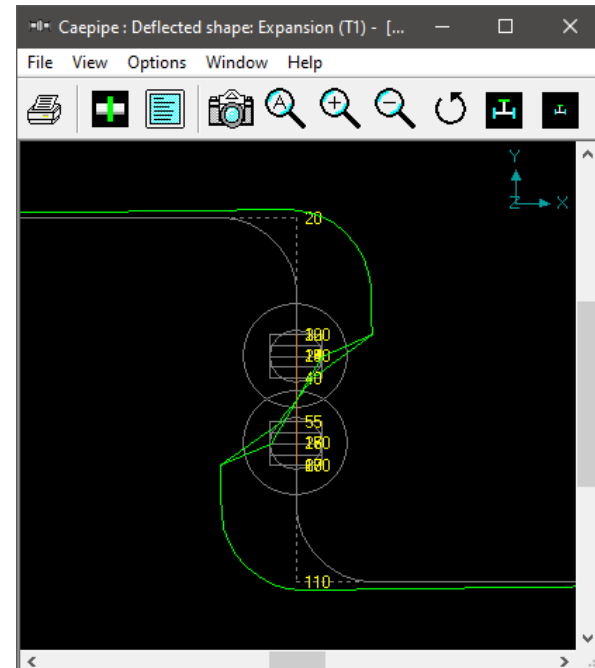

Example 6: Pressure Balanced Elbow Expansion Joint

Pressure Balanced Elbow Expansion Joints can consist of a single or double bellows in the flow section, and a balancing bellow of equal area on the back side of the elbow. Tie rods attach the outboard end of the balancing bellow to the outboard end of the flow bellows. Under pressure, the tie rods are loaded with the pressure thrust force. If the flow bellows compresses in service, the balancing bellow extends by the same amount without exposing the adjacent anchors to pressure thrust forces. However, the spring forces associated with bellows movements are imposed on the adjacent equipment. A pressure balanced elbow type expansion joint can accept ***axial compression, axial extension, lateral movements and very limited angular motion.***

The sample model shown below simulates the Pressure Balanced Elbow Expansion Joint with Four Tie Rods using the CAEPIPE's Tie Rod elements. The stiffness of the tie rods can be input explicitly (in this case, stiffness corresponding to 1" dia tie rod is input). See snap shots below for details.

The screenshot shows the CAEPIPE software interface with a table of element data. The table has columns for #, Node, Type, DX (ft'in'), DY (ft'in'), DZ (ft'in'), Matl, Sect, Load, and Data. The table is divided into sections: 'Pressure Balancing Elbow Expansion Joint' (rows 1-10), 'Tie Rods and Rigids' (rows 11-27), and 'Tie Rods' (rows 28-30). The 'Tie Rods and Rigids' section shows rigid elements connecting nodes 20, 100, 110, 120, 140, 160, and 200 to nodes 20, 80, and 140. The 'Tie Rods' section shows elements connecting nodes 90 and 140 to nodes 20 and 80.

#	Node	Type	DX (ft'in')	DY (ft'in')	DZ (ft'in')	Matl	Sect	Load	Data
1	Title = Pressure Balancing Elbow Expansion Joint								
2	10	From							Anchor
3	20		3'0"			A53	10	L1	
4	30	Bellows	0'9"			A53	10	L1	
5	40	Bend	2'0"			A53	10	L1	
6	50	Bend		-8'0"		A53	10	L1	
7	60		15'0"			A53	10	L1	Anchor
8	40A	From							
9	70		2'0"			A53	10	L1	
10	80	Bellows	0'9"			A53	10	L1	
11	Tie Rods and Rigids								
12	20	From							
13	90	Rigid		0.7071	0.7071	A53	1	L0	
14	20	From							
15	100	Rigid		-0.7071	0.7071	A53	1	L0	
16	20	From							
17	110	Rigid		-0.7071	-0.7071	A53	1	L0	
18	20	From							
19	120	Rigid		0.7071	-0.7071	A53	1	L0	
20	80	From							
21	140	Rigid		0.7071	0.7071	A53	1	L0	
22	80	From							
23	160	Rigid		-0.7071	0.7071	A53	1	L0	
24	80	From							
25	180	Rigid		-0.7071	-0.7071	A53	1	L0	
26	80	From							
27	200	Rigid		0.7071	-0.7071	A53	1	L0	
28	Tie Rods								
29	90	From							
30	140	Tie rod							

Bellows from 20 to 30 ✕

Axial stiffness (lb/inch)

Bending stiffness (in-lb/deg)

Torsional stiffness (in-lb/deg)

Lateral stiffness (lb/inch)

Pressure thrust area (in²)

Weight (lb)

Mean diameter (inch)

Tie rod from 90 to 140 ? ✕

	Tension	Compression	
Stiffness	<input type="text" value="2.500E+6"/>	<input type="text" value="2.500E+6"/>	(lb/inch)
Gap	<input type="text" value="0"/>	<input type="text" value="0"/>	(inch)