

Tutorial on Evaluation of Nozzles by computing Local Shell Stresses as per WRC 537 and Stress Evaluation as per ASME Section VIII Division 2 using CAEPIPE

General

Whenever Pressure Vessel or Heat exchanger (Static Equipment) nozzle loads exceed the allowable values provided by the Vendor (Equipment manufacturer), the piping stress professional is permitted to use WRC 107 (or WRC 537 or any other FEA) to calculate the local shell stresses at the Nozzle-Shell junction and evaluate those stresses with allowable values provided by an appropriate ASME Code. If the stresses are found to be within those allowable values, then the nozzle loads computed by pipe stress analysis are considered as acceptable.

This tutorial provides stepwise procedure to

1. Model the nozzle-to-shell junction as “Nozzle” to incorporate local shell flexibility.
2. Compute Loads on Nozzle by performing piping flexibility analysis.
3. Compute Local Shell Stresses at Nozzle attached to Cylindrical Vessel as per WRC 537 and
4. Evaluate Stresses as per ASME Section VIII Division 2.

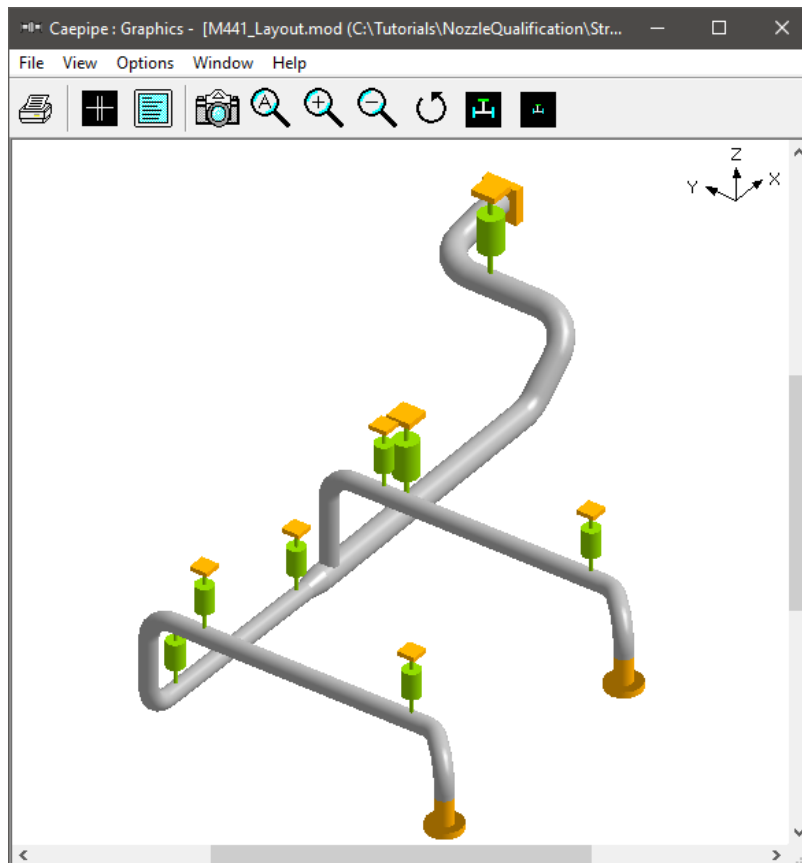

Step 1:

Pipe stress model for the layout shown above is first developed using CAEPIPE. The model is supplied along with this tutorial.

Step 2:

In the above snap shot, Node 340 is connecting to Nozzle M1 of a Cylindrical Vessel as shown in the figure below.

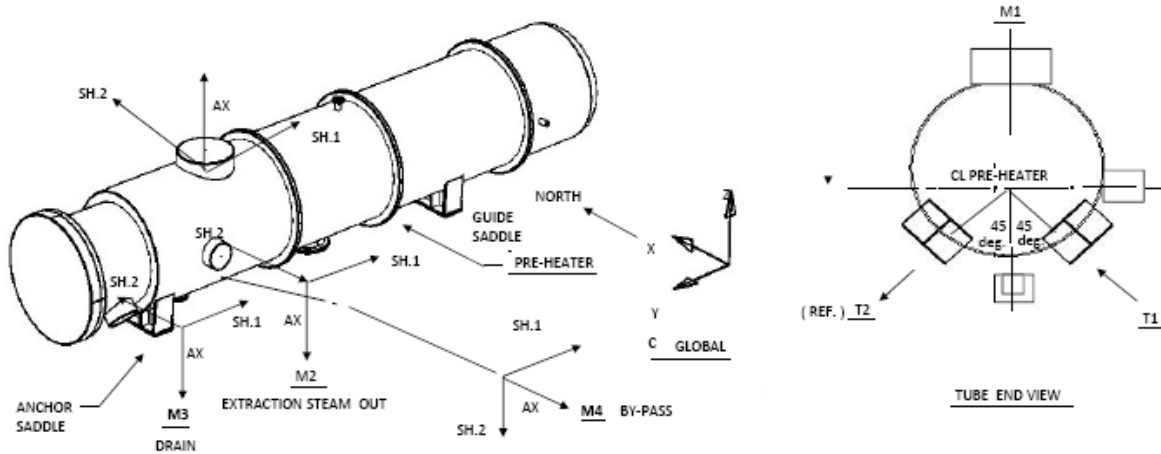

Vessel OD = 63" and Vessel Thickness = 0.35"
Nozzle OD = 22" and Nozzle Thickness = 1"

From the Equipment Datasheet, the following data were referred and listed below for quick reference.

1. Equipment Material = SA335 Grade P91
2. Maximum Metal Temperature (T) = 230 Deg. F
3. Minimum Metal Temperature (T_{ref}) = 70 Deg. F
4. Operating Pressure (P) = 15 psi
5. Peak Pressure during Occasional event = 20 psi
6. S_c = Basic Allowable Stress at Minimum Metal Temperature for the Shell = 35400 psi
7. S_h = Basic Allowable Stress at Maximum Metal Temperature for the Shell = 35400 psi

For example, as per Clause 5.2.2.4 of ASME Section VIII Division 2 (2017), the Allowable Stress (All) for both "Sustained" and "Sustained + Occasional" load case is to be entered as " $1.5S_h$ ", where S_h is the basic allowable stress at maximum metal temperature for Shell.

Similarly, as per Clause 5.5.6 of ASME Section VIII Division 2 (2017), the Allowable Stress (All) for Operating load case should be entered as " $3(S_c + S_h)/2 = 1.5(S_c + S_h)$ ", where S_c is the allowable stress at minimum metal temperature for Shell and S_h is defined above.

Sustained and Sustained + Occasional Allowable = $1.5S_h = 1.5 \times 35400 = 53100$ psi

Operating Allowable (All) = $1.5(S_c + S_h) = 1.5(35400 + 35400) = 106200$ psi

Step 3:

From the equipment drawings provided by the manufacturer as shown above, the properties are entered into CAEPIPE Nozzle at Node 340 for performing the flexibility analysis.

Nozzle at node 340

Nozzle Tag

Cylindrical Vessel Flat bottom tank

Spherical Vessel

Nozzle

OD (inch) Thk (inch)

Vessel

OD (inch) Thk (inch)

L1 (ft'in') L2 (ft'in')

Elastic modulus of vessel material (psi)

Vessel axis direction

X comp Y comp Z comp

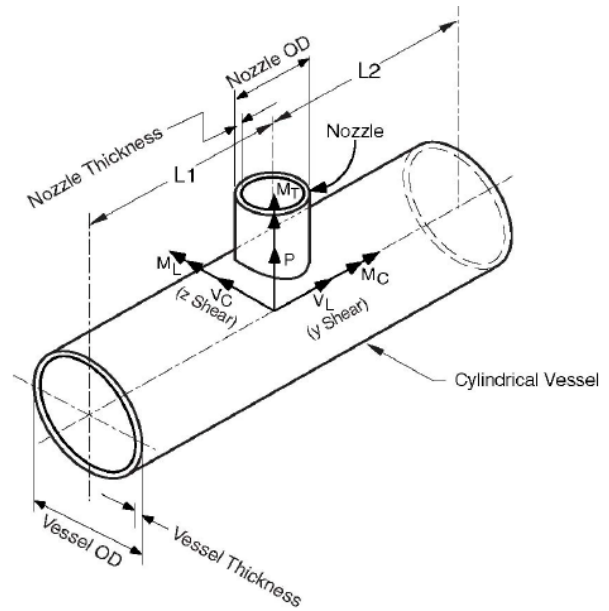

From the figure shown above, Lengths L1 and L2 on either side of the nozzle, which are the distances from the nozzle center line to the nearest location on vessel where the "ovalization deformation" of the vessel is stopped such as at a stiffener on the inner or outer surface of the vessel, or at the center of a saddle support to the vessel or at the junction to the enclosure (also called the head) or at a tube sheet inside the vessel etc.

Step 4:

Save the CAEPIPE model and perform the analysis through Layout window > File > Analyze. CAEPIPE will include in the pipe stress analysis the local shell stiffnesses internally computed. These local shell stiffnesses can be seen in CAEPIPE through Layout window > View > List > Nozzle stiffnesses.

Caepipe : Nozzle stiffnesses (2) - [M441_Layout.mod (C:\Tutorials\NozzleQualific...

File Edit Options Help

#	Node	Vess. Type	Radial (kp) (lb/inch)	Circumferential (kmc) (in-lb/deg)	Longitudinal (kml) (in-lb/deg)
1	340	Cyl	1.437E+7	70822.88	8.665E+5
2	620	Cyl	1.437E+7	70822.88	8.665E+5

Step 5:

Upon successful analysis, from the Support Loads results for different Load Cases, note down the forces and moments at Node 340 as shown below.

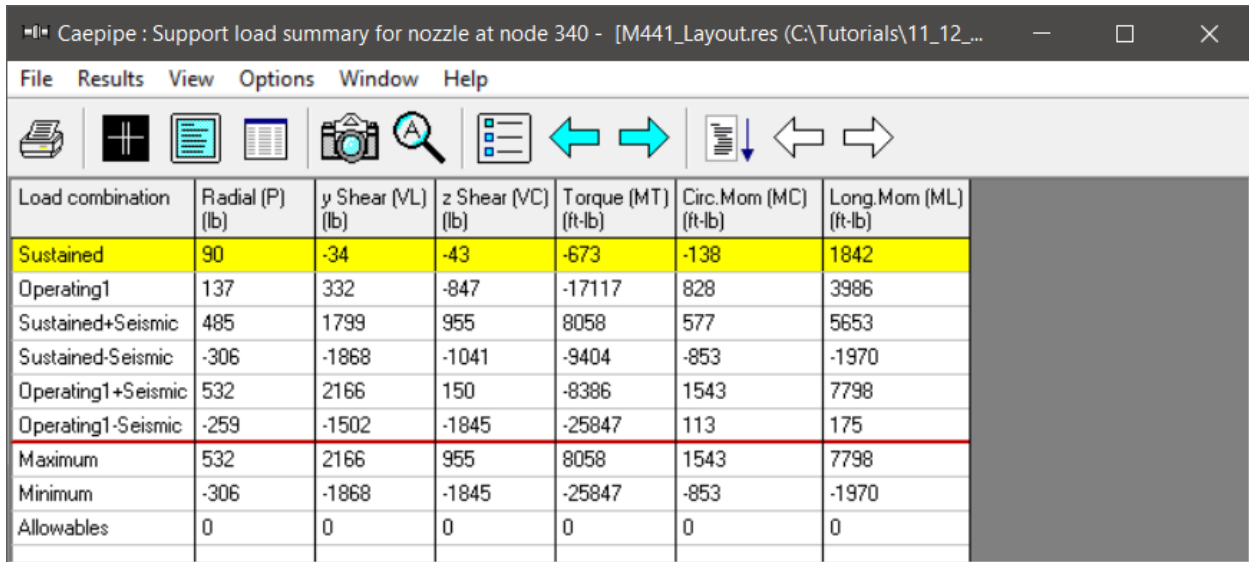

Load combination	Radial (P) (lb)	y Shear (VL) (lb)	z Shear (VC) (lb)	Torque (MT) (ft-lb)	Circ. Mom (MC) (ft-lb)	Long. Mom (ML) (ft-lb)
Sustained	90	-34	-43	-673	-138	1842
Operating1	137	332	-847	-17117	828	3986
Sustained+Seismic	485	1799	955	8058	577	5653
Sustained-Seismic	-306	-1868	-1041	-9404	-853	-1970
Operating1+Seismic	532	2166	150	-8386	1543	7798
Operating1-Seismic	-259	-1502	-1845	-25847	113	175
Maximum	532	2166	955	8058	1543	7798
Minimum	-306	-1868	-1845	-25847	-853	-1970
Allowables	0	0	0	0	0	0

Step 6:

As stated in the Section titled “Nozzle Evaluation” of CAEPIPE Technical Reference Manual, Pressure Stress at Shell (P_m) and Bending Stress at Shell (P_b) need to be manually calculated or determined using computer programs and input in the “Nozzle Evaluation” Module.

where,

P_m is the Average Primary Membrane Stress across the cross-section of the vessel away from Gross Structural Discontinuities such as a Nozzle and

P_b is the Primary Bending Stress (axial stress across the entire cross-section proportional to the distance from the Axis of the Vessel) due to “Primary” External Loads such as Weight, Wind, Earthquake, etc. away from Gross Structural Discontinuities such as a Nozzle.

As per the above document, for a Cylindrical Shell such as Pressure Vessel/Pre-heater/Tank, to be conservative, P_m due to Internal Pressure is the Circumferential Stress = $PD/2T$, where D is the Mean Diameter of the Cylinder.

So, P_m (for Sustained and Operating) = $15 \times (63-0.35)/(2 \times 0.35) = 1342.5$ psi.

P_m (for Sustained + Occasional) = $20 \times (63-0.35)/(2 \times 0.35) = 1790$ psi.

Similarly, in order to compute the Primary Bending Stress (P_b), a sample model shown below has been developed using CAEPIPE.

From the Analysis results, the Stresses obtained at Nozzle Location (Node 20) are as follows.

Caepipe : Pipe forces in local coordinates: Sustained (W+P) - [Preheater.res (C:\Tutorials_Rev27A...

File Results View Options Window Help

#	Node	Axial (lb)	y Shear (lb)	z Shear (lb)	Torsion(ft-lb)		Inplane(ft-lb)		Outplane(ft-lb)		Flex. Factors			SL (psi)
					Moment	SIF	Moment	SIF	Moment	SIF	FFi	FFo	FFt	
1	10	0	0	0	0		0		0					675
	20	0	476	0	0		-476		0					680
2	20	-21	-833	0	0		-952		0					685
	30	-21	-357	0	0		238		0					677
3	30	-21	-357	0	0		238		0					677
	40	-21	833	0	0		-952		0					685
4	40	0	-476	0	0		-476		0					680
	50	0	0	0	0		0		0					675

Caepipe : Pipe forces in local coordinates: Operating (W+P1+T1) - [Preheater.res (C:\Tutorials\Noz...

File Results View Options Window Help

#	Node	Axial (lb)	y Shear (lb)	z Shear (lb)	Torsion(ft-lb)		Inplane(ft-lb)		Outplane(ft-lb)		Flex. Factors			Sopr (psi)
					Moment	SIF	Moment	SIF	Moment	SIF	FFi	FFo	FFt	
1	10	0	0	0	0		0		0					675
	20	0	476	0	0		-476		0					680
2	20	-1669933	-833	0	0		-296993		0					20245
	30	-1669933	-357	0	0		-295803		0					20258
3	30	-1669933	-357	0	0		-295803		0					20258
	40	-1669933	833	0	0		-296993		0					20245
4	40	0	-476	0	0		-476		0					680
	50	0	0	0	0		0		0					675

Caepipe : Pipe forces in local coordinates: Seismic (g) - [Preheater.res (C:\Tutorials\NozzleQualific...

File Results View Options Window Help

#	Node	Axial (lb)	y Shear (lb)	z Shear (lb)	Torsion(ft-lb)		Inplane(ft-lb)		Outplane(ft-lb)		Flex. Factors			SL+S0 (psi)
					Moment	SIF	Moment	SIF	Moment	SIF	FFi	FFo	FFt	
1	10	0	0	0	0		0		0					675
	20	143	95	143	0		95		143					684
2	20	250	167	250	0		194		284					693
	30	107	72	107	0		51		72					680
3	30	107	72	107	0		51		72					680
	40	250	167	250	0		194		284					693
4	40	143	95	143	0		95		143					684
	50	0	0	0	0		0		0					675

Since ASME B31.3 is selected for Analysis, the Axial Stress term (F/A) is included in the Stress Calculations.

Step 7:

From the above steps, the data obtained are summarized below.

Sl. No	Description	Sustained	Sustained + Occasional *	Operating
1	Axial Load (P) (lb)	90	485	137
2	Shear Load (V _C) (lb)	-43	-1041	-847
3	Shear Load (V _L) (lb)	-34	-1868	332
4	Torsional Moment (M _T) (ft-lb)	-673	-9404	-17117
5	Circ. Moment (M _C) (ft-lb)	-138	-853	828
6	Longitudinal (M _L) (ft-lb)	1842	5653	3986
7	Pressure Stress at Shell (P _m) (psi)	1342.5	1790	1342.5
8	Bending Stress at Shell (P _b) (psi)	685	693	20245
9	Allowable Stress at Shell (A _{II})	53100	53100	106200

* Maximum Absolute (Signed) forces and moments of “Sustained + Seismic” and “Sustained – Seismic” are used for calculating local shell stresses for “Sustained + Occasional” load case.

Using the above data as well as the Vessel and Nozzle Parameters, create three (3) Nozzle Evaluation files corresponding to Sustained, Sustained + Occasional and Operating load cases.

Step 8:

Create “Nozzle Evaluation” File through CAEPIPE Main Frame > New > Nozzle Evaluation (.noz).

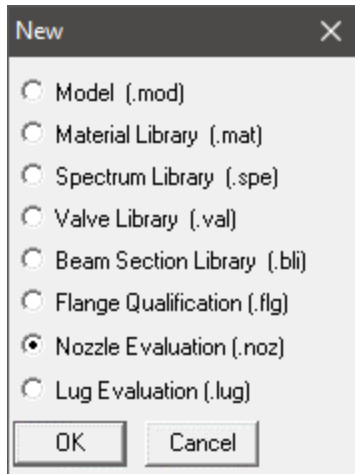

Double click on the Layout and input the values corresponding to Sustained load case in the Dialog Box as shown below.

The image shows a dialog box titled "Nozzle Evaluation" with a close button (X) in the top right corner. The dialog contains the following fields and controls:

- Code: Local Shell Stresses at Nozzles - WRC Bulletin 537 (dropdown menu)
- Radio buttons: Nozzle to Spherical Shell, Nozzle to Cylindrical Shell
- Load Case: Sustained (dropdown menu)
- Radial Load (P): 90 (lb)
- Shear Load (VC): -43 (lb)
- Shear Load (VL): -34 (lb)
- Circumferential Moment (MC): -138 (ft-lb)
- Longitudinal Moment (ML): 1842 (ft-lb)
- Torsional Moment (MT): -673 (ft-lb)
- Vessel Thickness (T): 0.35 (inch)
- Vessel Mean Radius (Rm): 31.325 (inch)
- Nozzle Outside Radius (ro): 11 (inch)
- Nozzle Thickness (t): 0 (inch)
- Nozzle Mean Radius (rm): 0 (inch)
- Fillet Radius (r): 1 (inch)
- Pressure Stress at Shell (Pm): 1343 (psi)
- Bending Stress at Shell (Pb): 685 (psi)
- Sustained Allowable [All]: 53100 (psi)
- Stress Conc. Factor - Tension (Kn): 0.00
- Stress Conc. Factor - Bending (Kb): 0.00

At the bottom of the dialog are two buttons: "OK" and "Cancel".

Save the file through File > Save and analyze through File > Analyze. The evaluation results obtained are shown below.

Caepipe : Nozzle Evaluation (54) - [M441_Sustained.noz (C:\Tutorials\NozzleQualification\Stresses)]

File Edit Options Help

Calculation of Local Stresses in Cylindrical Shells as per WRC Bulletin 537 (psi)

Stresses	Fig.No	Au	Al	Bu	Bl	Cu	Cl	Du	DI
Circumferential Membrane (P)	3C	-29	-29	-29	-29	-29	-29	-29	-29
Circumferential Bending (P)	2C-1	0	0	0	0	0	0	0	0
Circumferential Bending (P)	1C	0	0	0	0	0	0	0	0
Circumferential Membrane (MC)	3A	0	0	0	0	49	49	-49	-49
Circumferential Bending (MC)	1A	0	0	0	0	0	0	0	0
Circumferential Membrane (ML)	3B	-1311	-1311	1311	1311	0	0	0	0
Circumferential Bending (ML)	1B-1	0	0	0	0	0	0	0	0
Circumferential Stresses (Sp)	-	-1341	-1341	1282	1282	19	19	-78	-78
Longitudinal Membrane (P)	4C	-88	-88	-88	-88	-88	-88	-88	-88
Longitudinal Bending (P)	1C-1	0	0	0	0	0	0	0	0
Longitudinal Bending (P)	2C	0	0	0	0	0	0	0	0
Longitudinal Membrane (MC)	4A	0	0	0	0	190	190	-190	-190
Longitudinal Bending (MC)	2A	0	0	0	0	0	0	0	0
Longitudinal Membrane (ML)	4B	-700	-700	700	700	0	0	0	0
Longitudinal Bending (ML)	2B-1	0	0	0	0	0	0	0	0
Longitudinal Stresses (Sx)	-	-788	-788	612	612	102	102	-277	-277
Shear Stress (V1)	-	-4	-4	4	4	0	0	0	0
Shear Stress (V2)	-	0	0	0	0	3	3	-3	-3
Shear Stress (MT)	-	-30	-30	-30	-30	-30	-30	-30	-30
Shear Stresses (Z)	-	-34	-34	-27	-27	-28	-28	-33	-33
Combined Stress Intensity (PI)	-	1343	1343	1283	1283	110	110	283	283
Stress Compliance as per ASME Section VIII Division 2 - Sustained Load									
		Calculated	Allowed	Ratio	Status				
Stress (Pm+Pb+PI) (psi)		3371	53100	0.063	Pass				

Similarly, create two (2) other models corresponding to “Sustained + Occasional” and “Operating” load cases as shown below.

Nozzle Evaluation



Code

Nozzle to Spherical Shell Nozzle to Cylindrical Shell

Load Case

Radial Load (P) (lb)

Shear Load (VC) (lb)

Shear Load (VL) (lb)

Circumferential Moment (MC) (ft-lb)

Longitudinal Moment (ML) (ft-lb)

Torsional Moment (MT) (ft-lb)

Vessel Thickness (T) (inch)

Vessel Mean Radius (Rm) (inch)

Nozzle Outside Radius (ro) (inch)

Nozzle Thickness (t) (inch)

Nozzle Mean Radius (rm) (inch)

Fillet Radius (r) (inch)

Pressure Stress at Shell (Pm) (psi)

Bending Stress at Shell (Pb) (psi)

Sustained + Occasional Allowable [All] (psi)

Stress Conc. Factor - Tension (Kn)

Stress Conc. Factor - Bending (Kb)

OK

Cancel



Calculation of Local Stresses in Cylindrical Shells as per WRC Bulletin 537 (psi)

Stresses	Fig.No	Au	Al	Bu	Bl	Cu	Cl	Du	DI
Circumferential Membrane (P)	3C	-158	-158	-158	-158	-158	-158	-158	-158
Circumferential Bending (P)	2C-1	0	0	0	0	0	0	0	0
Circumferential Bending (P)	1C	0	0	0	0	0	0	0	0
Circumferential Membrane (MC)	3A	0	0	0	0	301	301	-301	-301
Circumferential Bending (MC)	1A	0	0	0	0	0	0	0	0
Circumferential Membrane (ML)	3B	-4025	-4025	4025	4025	0	0	0	0
Circumferential Bending (ML)	1B-1	0	0	0	0	0	0	0	0
Circumferential Stresses (Sp)	-	-4183	-4183	3867	3867	143	143	-459	-459
Longitudinal Membrane (P)	4C	-473	-473	-473	-473	-473	-473	-473	-473
Longitudinal Bending (P)	1C-1	0	0	0	0	0	0	0	0
Longitudinal Bending (P)	2C	0	0	0	0	0	0	0	0
Longitudinal Membrane (MC)	4A	0	0	0	0	1172	1172	-1172	-1172
Longitudinal Bending (MC)	2A	0	0	0	0	0	0	0	0
Longitudinal Membrane (ML)	4B	-2148	-2148	2148	2148	0	0	0	0
Longitudinal Bending (ML)	2B-1	0	0	0	0	0	0	0	0
Longitudinal Stresses (Sx)	-	-2621	-2621	1675	1675	699	699	-1645	-1645
Shear Stress (V1)	-	-86	-86	86	86	0	0	0	0
Shear Stress (V2)	-	0	0	0	0	154	154	-154	-154
Shear Stress (MT)	-	-424	-424	-424	-424	-424	-424	-424	-424
Shear Stresses (Z)	-	-510	-510	-338	-338	-270	-270	-579	-579
Combined Stress Intensity (PI)	-	4335	4335	3918	3918	808	808	1881	1881

Stress Compliance as per ASME Section VIII Division 2 - Sustained + Occasional Load

	Calculated	Allowed	Ratio	Status
Stress (Pm+Pb+PI) (psi)	6818	53100	0.128	Pass

Nozzle Evaluation



Code

Nozzle to Spherical Shell Nozzle to Cylindrical Shell

Load Case

Radial Load (P) (lb)

Shear Load (VC) (lb)

Shear Load (VL) (lb)

Circumferential Moment (MC) (ft-lb)

Longitudinal Moment (ML) (ft-lb)

Torsional Moment (MT) (ft-lb)

Vessel Thickness (T) (inch)

Vessel Mean Radius (Rm) (inch)

Nozzle Outside Radius (ro) (inch)

Nozzle Thickness (t) (inch)

Nozzle Mean Radius (rm) (inch)

Fillet Radius (r) (inch)

Pressure Stress at Shell (Pm) (psi)

Bending Stress at Shell (Pb) (psi)

Operating Allowable [All] (psi)

Stress Conc. Factor - Tension (Kn)

Stress Conc. Factor - Bending (Kb)

OK

Cancel

Caepipe : Nozzle Evaluation (54) - [M441_Operating.noz (C:\Tutorials\NozzleQualification\Stresses)]									
File Edit Options Help									
Calculation of Local Stresses in Cylindrical Shells as per WRC Bulletin 537 (psi)									
Stresses	Fig.No	Au	Al	Bu	Bl	Cu	Cl	Du	DI
Circumferential Membrane (P)	3C	-45	-45	-45	-45	-45	-45	-45	-45
Circumferential Bending (P)	2C-1	-52	52	-52	52	0	0	0	0
Circumferential Bending (P)	1C	0	0	0	0	-229	229	-229	229
Circumferential Membrane (MC)	3A	0	0	0	0	-292	-292	292	292
Circumferential Bending (MC)	1A	0	0	0	0	-3111	3111	3111	-3111
Circumferential Membrane (ML)	3B	-2838	-2838	2838	2838	0	0	0	0
Circumferential Bending (ML)	1B-1	-2051	2051	2051	-2051	0	0	0	0
Circumferential Stresses (Sp)	-	-4985	-780	4792	795	-3677	3003	3130	-2635
Longitudinal Membrane (P)	4C	-134	-134	-134	-134	-134	-134	-134	-134
Longitudinal Bending (P)	1C-1	-151	151	-151	151	0	0	0	0
Longitudinal Bending (P)	2C	0	0	0	0	58	-58	58	-58
Longitudinal Membrane (MC)	4A	0	0	0	0	-1138	-1138	1138	1138
Longitudinal Bending (MC)	2A	0	0	0	0	-1184	1184	1184	-1184
Longitudinal Membrane (ML)	4B	-1515	-1515	1515	1515	0	0	0	0
Longitudinal Bending (ML)	2B-1	-3612	3612	3612	-3612	0	0	0	0
Longitudinal Stresses (Sx)	-	-5412	2115	4843	-2080	-2398	-145	2247	-238
Shear Stress (V1)	-	-70	-70	70	70	0	0	0	0
Shear Stress (V2)	-	0	0	0	0	-27	-27	27	27
Shear Stress (MT)	-	-772	-772	-772	-772	-772	-772	-772	-772
Shear Stresses (Z)	-	-842	-842	-702	-702	-799	-799	-744	-744
Combined Stress Intensity (PL+Q)	-	6067	3349	5520	3199	4061	3531	3554	2847
Stress Compliance as per ASME Section VIII Division 2 - Operating Load									
		Calculated	Allowed	Ratio	Status				
Stress (Pm+Pb+Pl+Q) (psi)		27655	106200	0.260	Pass				

Step 9:

From the Evaluation Results, it is observed that as per Clauses 5.2.2.4 and 5.5.6 of ASME Section VIII Division 2 (2017), the Local Shell Stresses Computed at Nozzle meets the requirements.

1. Sustained Stress (Pm+Pb+Pl) = **3371 psi < 53100 psi.**
2. Sustained + Occasional Stress (Pm+Pb+Pl) = **6818 psi < 53100 psi** and
3. Operating Stress (Pm+Pb+Pl+Q) = **27655 psi < 106200 psi**

Note:

CAEPIPE Models, Material Properties Referred and Nozzle Evaluation Files created are supplied along with the tutorial package for reference.