

## Tutorial for Modeling Victaulic Coupling in CAEPIPE

The following are the Steps for modeling and including Victaulic Coupling in CAEPIPE analysis.

### General

- **Victaulic** is a developer and producer of mechanical pipe joining systems and is the originator of the grooved pipe couplings joining system.
- Victaulic Grooved Couplings are used to join mechanical pipes together. Grooved coupling pipe joining systems use a roll grooving technique to join pipes and pipe joining components. A groove is placed on the end of two pipes to prepare the pipes engagement with the coupling housing and gasket. The gasket creates a pressure responsive seal on the outside diameter of the pipe, unlike standard compression joints, where pressure acts to separate the seal. The gasket sealing is enhanced as the coupling housing is tightened onto the pipe end. "The economics of the grooved method derive from simplified assembly that involves three basic concepts: a pressure responsive gasket that creates a leak-tight seal; couplings that hold the pipe together; and fasteners that secure the couplings.

Mechanical piping joining systems are being used in HVAC, plumbing, fire protection and mining, water and waste water treatment, oilfield operations, power plants, military, marine systems and other industrial applications due to the time and labor-saving features associated with installation. Mechanical piping joining systems offer an alternative to welding, threading, and flanging for joining two pipe ends. See the figures given below for details.

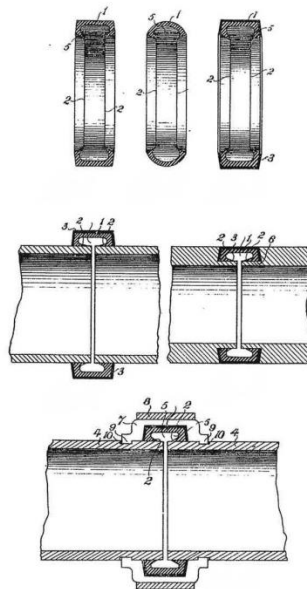

- The steps provided in this tutorial are applicable for most of the Victaulic Couplings, including Styles 77 and 177. The properties from Style 77 are referred from the document available in the link <http://static.victaulic.com/assets/uploads/literature/06.04.pdf>. Dimensional details and mechanical properties of Victaulic Coupling are referred from the document given in the above link corresponding to 6" Victaulic Coupling. The same is presented below for quick reference.

## 4.0 DIMENSIONS

### Style 77

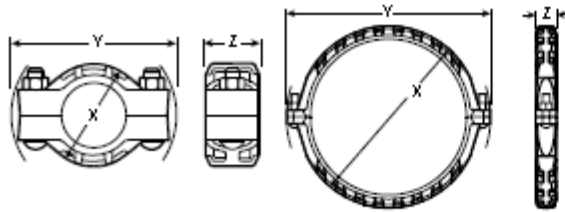

¾ – 12"20 – 300 mm sizes

14 – 24"350 – 600 mm sizes

| Size              |                                   | Working Pressure <sup>3</sup> | End Load <sup>3</sup> | Pipe End Separation <sup>4</sup> | Deflection from Centerline <sup>4</sup> |                      | Bolt/Nut <sup>5</sup> |             | Dimensions   |              |             | Weight               |
|-------------------|-----------------------------------|-------------------------------|-----------------------|----------------------------------|---|----------------------|-----------------------|-------------|--------------|--------------|-------------|----------------------|
| Nominal inches DN | Actual Outside Diameter inches mm | Maximum psi kPa               | Maximum lb N          | Allowable inches mm              | Per Cplg. Degrees                       | Pipe inches/ft. mm/m | Qty.                  | Size inches | X inches mm  | Y inches mm  | Z inches mm | Approx. (Each) lb kg |
|                   | 5.250<br>133.0                    | 1000<br>6900                  | 21,635<br>96275       | 0-0.13<br>0-3.2                  | 1°-21'                                  | 0.28<br>24           | 2                     | 20 x 108    | 7.63<br>194  | 10.38<br>264 | 2.13<br>54  | 100<br>4.5           |
| DN125             | 5.500<br>139.7                    | 1000<br>6900                  | 23,745<br>105665      | 0-0.13<br>0-3.2                  | 1°-18'                                  | 0.28<br>24           | 2                     | 20 x 108    | 8.63<br>219  | 10.65<br>270 | 2.13<br>54  | 100<br>4.5           |
| 6<br>DN150        | 6.625<br>168.3                    | 1000<br>6900                  | 34,470<br>153390      | 0-0.13<br>0-3.2                  | 1°-5'                                   | 0.23<br>18           | 2                     | ¾ x 4¾      | 8.63<br>219  | 11.88<br>302 | 2.13<br>54  | 120<br>5.4           |
|                   | 6.250<br>159.0                    | 1000<br>6900                  | 30,665<br>136460      | 0-0.13<br>0-3.2                  | 1°-9'                                   | 0.24<br>20           | 2                     | 20 x 108    | 8.63<br>219  | 11.50<br>292 | 2.13<br>54  | 132<br>6.0           |
|                   | 6.500<br>165.1                    | 1000<br>6900                  | 33,185<br>147660      | 0-0.13<br>0-3.2                  | 1°-6'                                   | 0.23<br>19           | 2                     | ¾ x 4¾      | 8.88<br>226  | 11.63<br>295 | 2.13<br>54  | 132<br>6.0           |
| 8"<br>DN200       | 8.625<br>219.1                    | 800<br>5500                   | 46,740<br>207995      | 0-0.13<br>0-3.2                  | 0°-50'                                  | 0.18<br>14           | 2                     | ¾ x 5       | 11.00<br>279 | 14.75<br>375 | 2.50<br>63  | 208<br>9.4           |
| 10"<br>DN250      | 10.750<br>273.0                   | 800<br>5500                   | 73,280<br>326100      | 0-0.13<br>0-3.2                  | 0°-40'                                  | 0.14<br>12           | 2                     | 1 x 6       | 13.63<br>346 | 17.13<br>435 | 2.63<br>67  | 278<br>12.6          |
| 12"<br>DN300      | 12.750<br>323.9                   | 800<br>5500                   | 102,000<br>453900     | 0-0.13<br>0-3.2                  | 0°-34'                                  | 0.12<br>9            | 2                     | 1 x 6½      | 15.63<br>397 | 19.25<br>489 | 2.63<br>67  | 311<br>14.1          |
| 14"<br>DN350      | 14.000<br>355.6                   | 300<br>2065                   | 46,180<br>205500      | 0-0.13<br>0-3.2                  | 0°-31'                                  | 0.11<br>9            | 2                     | 1 x 3½      | 16.75<br>425 | 20.25<br>514 | 3.00<br>76  | 392<br>17.8          |
|                   | 14.842<br>377.0                   | 300<br>2065                   | 51,875<br>230,845     | 0-0.13<br>0-3.2                  | 0°-31'                                  | 0.11<br>9            | 2                     | 1 x 3½      | 17.39<br>442 | 20.96<br>531 | 2.80<br>71  | 488<br>22.1          |
| 16"<br>DN400      | 16.000<br>406.4                   | 300<br>2065                   | 60,320<br>268425      | 0-0.13<br>0-3.2                  | 0°-27'                                  | 0.10<br>9            | 2                     | 1 x 3½      | 18.75<br>476 | 22.25<br>565 | 3.00<br>76  | 45<br>20.4           |
|                   | 16.772<br>426.0                   | 300<br>2065                   | 66,245<br>294,795     | 0-0.13<br>0-3.2                  | 0°-27'                                  | 0.10<br>9            | 2                     | 1 x 3½      | 19.69<br>500 | 22.92<br>581 | 2.92<br>74  | 56.7<br>25.7         |
| 18"<br>DN450      | 18.000<br>457.2                   | 300<br>2065                   | 76,340<br>339710      | 0-0.13<br>0-3.2                  | 0°-24'                                  | 0.08<br>7            | 2                     | 1½ x 4      | 21.56<br>548 | 25.00<br>635 | 3.13<br>80  | 64.1<br>29.1         |
|                   | 18.898<br>480.0                   | 300<br>2065                   | 84,105<br>374,265     | 0-0.13<br>0-3.2                  | 0°-24'                                  | 0.08<br>7            | 2                     | 1½ x 4      | 22.38<br>569 | 25.86<br>655 | 3.04<br>77  | 77.2<br>35           |

- 3 Working Pressure and End Load are total, from all internal and external loads, based on standard weight (ANSI) steel pipe, standard roll or cut groove in accordance with Victaulic specifications. Contact Victaulic for performance on other pipe.
- 4 Allowable Pipe End Separation and Deflection figures show the maximum nominal range of movement available at each joint for standard roll grooved pipe. Figures for standard cut grooved pipe may be doubled. These figures are maximums; for design and installation purposes these figures should be reduced by: 50% for ¾ – 3 ½"20 – 90 mm; 25% for 4"100 mm and larger.
- 5 Number of bolts required equals number of housing segments.
- 6 Couplings 8, 10, 12"200, 250, 300 mm sizes available to JIS standards. Refer to Victaulic submittal [publication 06.17](#) for details.
- 7 For 14 – 72"350 – 1800 mm Roll Groove systems Victaulic offers the Advanced Groove System (AGS) line of products. Refer to Victaulic submittal [publication 20.03](#) for information on the Style W77 flexible AGS coupling.

#### NOTES

- + Metric thread size bolts are available (color coded gold) for all coupling sizes upon request. Contact Victaulic for details.
- + WARNING: FOR ONE TIME FIELD TEST ONLY, the Maximum Joint Working Pressure may be increased to 1½ times the figures shown.

The .pdf file of the details of Style 77 Victaulic Couplings downloaded from the link mentioned above is attached herewith for convenience.

# Tutorial

## Step 1:

Attached are the two sample CAEPIPE models with identical layouts with one model having a Temperature Increase and the other with a Temperature Decrease to simulate the Coupling under Compression and Tension respectively. Snapshots of the piping layout are shown below.

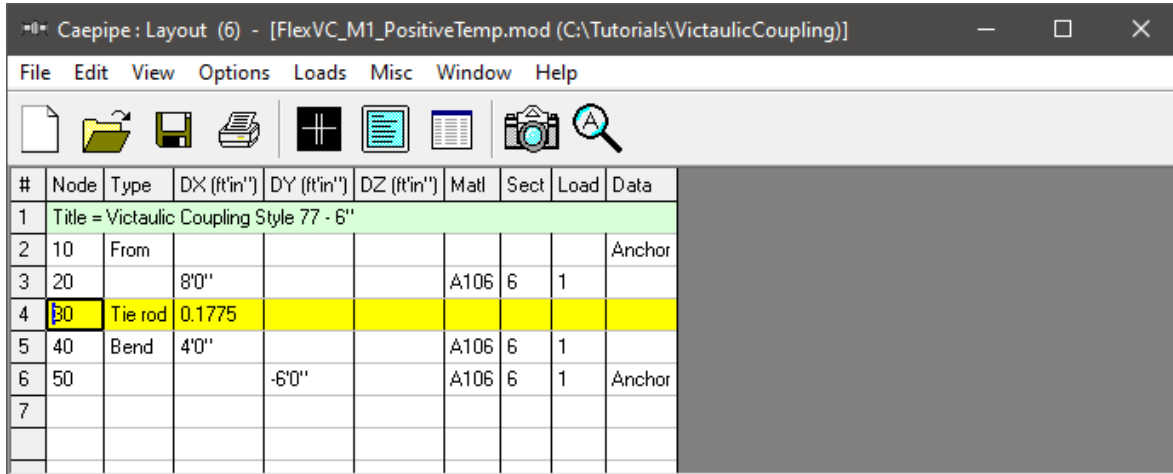

The screenshot shows the 'Caepipe: Layout (6)' window. The table below represents the data shown in the interface:

| # | Node                                     | Type    | DX (ft'in') | DY (ft'in') | DZ (ft'in') | Matl | Sect | Load | Data   |
|---|--|---------|-------------|-------------|-------------|------|------|------|--------|
| 1 | Title = Victaulic Coupling Style 77 - 6" |         |             |             |             |      |      |      |        |
| 2 | 10                                       | From    |             |             |             |      |      |      | Anchor |
| 3 | 20                                       |         | 8'0"        |             |             | A106 | 6    | 1    |        |
| 4 | 30                                       | Tie rod | 0.1775      |             |             |      |      |      |        |
| 5 | 40                                       | Bend    | 4'0"        |             |             | A106 | 6    | 1    |        |
| 6 | 50                                       |         |             | -6'0"       |             | A106 | 6    | 1    | Anchor |
| 7 |  |         |             |             |             |      |      |      |        |

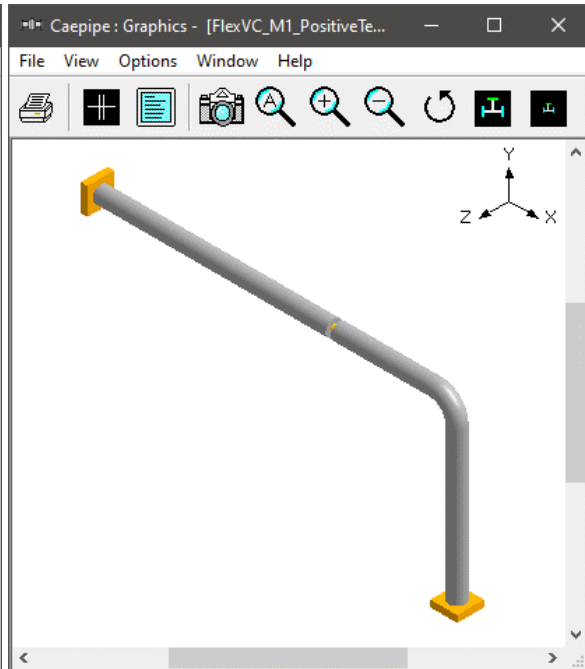
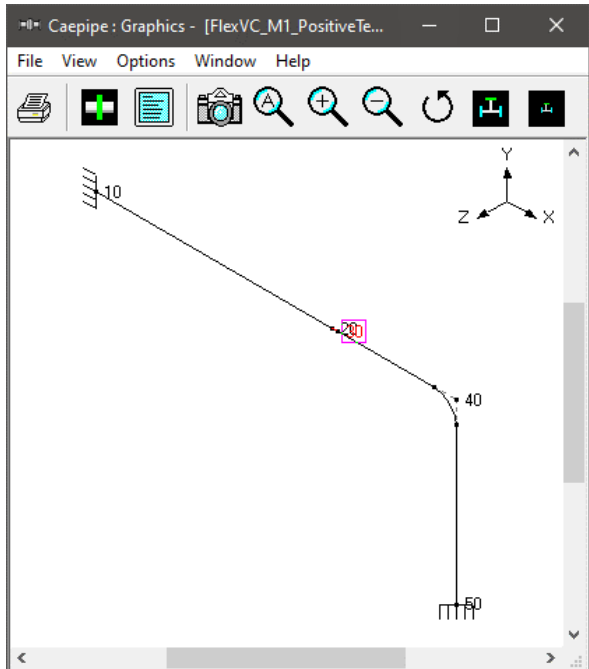

| # | Name | Description  | Type | Density (lb/in <sup>3</sup> ) | Nu  | Joint factor | # | Temp (F) | E (psi) | Alpha (in/in/F) | Allowable (psi) |
|---|------|--------------|------|-------------------------------|-----|--------------|---|----------|---------|-----------------|-----------------|
| 1 | A106 | A106 Grade A | CS   | 0.283                         | 0.3 | 1.00         | 1 | -20      | 29.9E+6 | 6.50E-6         | 30000           |
| 2 |      |              |      |                               |     |              | 2 | 70       | 29.5E+6 | 6.50E-6         | 30000           |
|   |      |              |      |                               |     |              | 3 | 100      | 29.3E+6 | 6.50E-6         | 30000           |
|   |      |              |      |                               |     |              | 4 | 150      | 29.1E+6 | 6.50E-6         | 30000           |
|   |      |              |      |                               |     |              | 5 | 200      | 28.8E+6 | 6.50E-6         | 30000           |
|   |      |              |      |                               |     |              | 6 | 300      | 28.6E+6 | 6.50E-6         | 30000           |
|   |      |              |      |                               |     |              | 7 |          |         |                 |                 |

| # | Name | T1 (F) | P1 (psi) | Desg.T (F) | Desg.Pr. (psi) | Specific gravity | Add.Wgt. (lb/ft) | Wind Load 1 | Wind Load 2 | Wind Load 3 | Wind Load 4 |
|---|------|--------|----------|------------|----------------|------------------|------------------|-------------|-------------|-------------|-------------|
| 1 | 1    | 170    | 400      | 170        | 400            |                  |                  |             |             |             |             |
| 2 |      |        |          |            |                |                  |                  |             |             |             |             |

| # | Name | Nom Dia | Sch | OD (inch) | Thk (inch) | Cor.Al (inch) | M.Tol (%) | Ins.Dens (lb/ft <sup>3</sup> ) | Ins.Thk (inch) | Lir (lb) |
|---|------|---------|-----|-----------|------------|---------------|-----------|--------------------------------|----------------|----------|
| 1 | 5    | 6"      | 10S | 6.625     | 0.134      |               |           |                                |                |          |
| 2 |      |         |     |           |            |               |           |                                |                |          |

### Step 2:

From the attached models, you may observe that the Flexible Victaulic Coupling is modelled between Nodes 20 and 30 using Tie Rod by entering the properties listed in Step 3 below from the catalog for Victaulic Flexible Coupling, Style 77- Roll Groove Type (shown above).

### Step 3:

- Axial Stiffness of the Tie Rod =  $AE/L = 24.02 \times 29.5E+6 / 2.13 = 3.327E+8 \text{ lb/inch}$   
where,  
A = Area of the Coupling calculated using the dimensions "X" and "Actual Outer Diameter" provided in the catalogue ( $= \text{PI}()/4 * (8.630^2 - 6.625^2)$  in from the attached model) = **24.02 in<sup>2</sup>**  
E = Young's Modulus of the Coupling Material = **29.5E+6 psi** (taken from properties for A106 Grade A, as the material for the Coupling is not listed in the catalog)  
L = **2.13"** (Z value from Catalog for 6" Coupling)
- Gap in Tension = **0.13"** (= Maximum Separation for Roll Groove – Minimum Separation for Roll Groove = 0.13" – 0.0")
- Gap in Compression = **0"** (as the coupler cannot compress any further beyond Minimum Separation)

The above parameters are entered for Tie Rod between Node 20 and 30, as shown in the snapshot below.

Tie rod from 20 to 30 ? X

|           |             |
|-----------|-------------|
| Tension   | Compression |
| Stiffness | Stiffness   |
| 3.327E+8  | 3.327E+8    |
| (lb/inch) | (lb/inch)   |
| Gap       | Gap         |
| 0.13      | 0           |
| (inch)    | (inch)      |

#### Step 4:

Select the Load Cases shown below for analysis through Layout Window > Loads > Load cases. Save the model and perform the analysis through Layout window > File > Analyze.

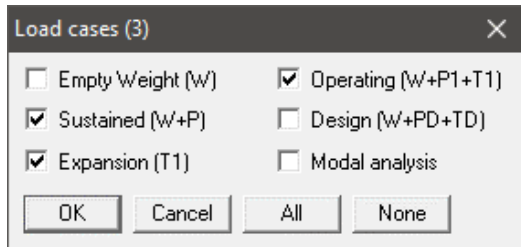

#### Step 5:

From the Displacements and Element forces results of CAEPIPE for “Operating (W+P1+T1)” Load case for the model with temperature Increase, note the following.

Caepipe : Displacements: Operating (W+P1+T1) - [FlexVC\_M1\_PositiveTemp.res (C:\Tutorials\Victaulic...]

| # | Node | Displacements (global) |          |          |          |          |          |
|---|------|------------------------|----------|----------|----------|----------|----------|
|   |      | X (inch)               | Y (inch) | Z (inch) | XX (deg) | YY (deg) | ZZ (deg) |
| 1 | 10   | 0.000                  | 0.000    | 0.000    | 0.0000   | 0.0000   | 0.0000   |
| 2 | 20   | 0.068                  | -0.020   | 0.000    | 0.0000   | 0.0000   | -0.0154  |
| 3 | 30   | 0.068                  | 0.155    | 0.000    | 0.0000   | 0.0000   | -0.1228  |
| 4 | 40A  | 0.096                  | 0.071    | 0.000    | 0.0000   | 0.0000   | -0.1239  |
| 5 | 40B  | 0.082                  | 0.045    | 0.000    | 0.0000   | 0.0000   | -0.1150  |
| 6 | 50   | 0.000                  | 0.000    | 0.000    | 0.0000   | 0.0000   | 0.0000   |

Caepipe : Pipe forces in local coordinates: Operating (W+P1+T1) - [FlexVC\_M1\_PositiveTemp.res (C:\T...]

| # | Node | Axial (lb) | y Shear (lb) | z Shear (lb) | Torsion(ft-lb) |     | Inplane(ft-lb) |      | Outplane(ft-lb) |      | Flex. Factors |       |     | Sopr (psi) |
|---|------|------------|--------------|--------------|----------------|-----|----------------|------|-----------------|------|---------------|-------|-----|------------|
|   |      |            |              |              | Moment         | SIF | Moment         | SIF  | Moment          | SIF  | FFi           | FFo   | FFt |            |
| 1 | 10   | -356       | -74          | 0            | 0              |     | -297           |      | 0               |      |               |       |     | 5634       |
|   | 20   | -356       | 0            | 0            | 0              |     | 0              |      | 0               |      |               |       |     | 4814       |
| 2 | 30   | -356       | 0            | 0            | 0              |     | 0              |      | 0               |      |               |       |     | 4814       |
|   | 40A  | -356       | 30           | 0            | 0              |     | -49            |      | 0               |      |               |       |     | 4949       |
| 3 | 40A  | -356       | -30          | 0            | 0              |     | 49             | 3.05 | 0               | 2.54 | 12.07         | 12.07 |     | 5227       |
|   | 40B  | -41        | 356          | 0            | 0              |     | -192           | 3.05 | 0               | 2.54 | 12.07         | 12.07 |     | 6550       |
| 4 | 40B  | -41        | 356          | 0            | 0              |     | -192           |      | 0               |      |               |       |     | 5460       |
|   | 50   | -90        | 356          | 0            | 0              |     | -2062          |      | 0               |      |               |       |     | 10604      |

- The **differential Axial displacement** between Nodes 20 and 30 =  $\text{abs}[0.068 - (0.068)] = 0.0'' < 0.13''$  (Pipe End Separation specified in the catalog 0.13”).
- The **differential Angular Deflection** =  $\text{abs}[-0.0154 - (-0.1228)] = 0.107 \text{ deg} < 1.083 \text{ deg}$  (Allowable Deflection specified in the catalog).
- **Axial Load** at Tie Rod = **-356 lb** < **34470 lb** (End Load specified in the catalog)

### Step 6:

Similarly, from the Displacements and Element forces results of CAEPIPE for “Operating (W+P1+T1)” Load case for the model with Temperature Decrease (snapshot of load screen given below), note the following results.

| # | Name | T1 (F) | P1 (psi) | Desg.T (F) | Desg.Pr. (psi) | Specific gravity | Add.Wgt. (lb/ft) | Wind Load 1 | Wind Load 2 | Wind Load 3 | Wind Load 4 |
|---|------|--------|----------|------------|----------------|------------------|------------------|-------------|-------------|-------------|-------------|
| 1 | 1    | -30    | 400      | -30        | 400            |                  |                  |             |             |             |             |

| # | Node | Displacements (global) |          |          |          |          |          |
|---|------|------------------------|----------|----------|----------|----------|----------|
|   |      | X (inch)               | Y (inch) | Z (inch) | XX (deg) | YY (deg) | ZZ (deg) |
| 1 | 10   | 0.000                  | 0.000    | 0.000    | 0.0000   | 0.0000   | 0.0000   |
| 2 | 20   | -0.056                 | -0.020   | 0.000    | 0.0000   | 0.0000   | -0.0154  |
| 3 | 30   | 0.022                  | -0.064   | 0.000    | 0.0000   | 0.0000   | 0.0265   |
| 4 | 40A  | -0.001                 | -0.046   | 0.000    | 0.0000   | 0.0000   | 0.0255   |
| 5 | 40B  | -0.004                 | -0.037   | 0.000    | 0.0000   | 0.0000   | 0.0076   |
| 6 | 50   | 0.000                  | 0.000    | 0.000    | 0.0000   | 0.0000   | 0.0000   |

| # | Node | Axial (lb) | y Shear (lb) | z Shear (lb) | Torsion (ft-lb) |     | Inplane (ft-lb) |      | Outplane (ft-lb) |      | Flex. Factors |       |     | Sopr (psi) |
|---|------|------------|--------------|--------------|-----------------|-----|-----------------|------|------------------|------|---------------|-------|-----|------------|
|   |      |            |              |              | Moment          | SIF | Moment          | SIF  | Moment           | SIF  | FFi           | FFo   | FFt |            |
| 1 | 10   | 0          | -74          | 0            | 0               |     | -297            |      | 0                |      |               |       |     | 5764       |
|   | 20   | 0          | 0            | 0            | 0               |     | 0               |      | 0                |      |               |       |     | 4944       |
| 2 | 30   | 0          | 0            | 0            | 0               |     | 0               |      | 0                |      |               |       |     | 4944       |
|   | 40A  | 0          | 30           | 0            | 0               |     | -49             |      | 0                |      |               |       |     | 5079       |
| 3 | 40A  | 0          | -30          | 0            | 0               |     | 49              | 3.05 | 0                | 2.54 | 12.07         | 12.07 |     | 5357       |
|   | 40B  | -41        | 0            | 0            | 0               |     | 75              | 3.05 | 0                | 2.54 | 12.07         | 12.07 |     | 5557       |
| 4 | 40B  | -41        | 0            | 0            | 0               |     | 75              |      | 0                |      |               |       |     | 5135       |
|   | 50   | -90        | 0            | 0            | 0               |     | 75              |      | 0                |      |               |       |     | 5117       |

- The **differential Axial displacement** between Nodes 20 and 30 =  $\text{abs}[-0.056 - (0.022)] = 0.078'' < 0.13''$  (Pipe End Separation specified in the catalog 0.13”).
- The **differential Angular Deflection** =  $\text{abs}[-0.0154 - (0.0265)] = 0.0419 \text{ deg} < 1.083 \text{ deg}$  (Allowable Deflection specified in the catalog).
- **Axial Load** at Tie Rod = **0 lb** < **34470 lb** (End Load specified in the Catalog)

### Summary

From the above exercise, it is noted that the differential Axial displacement, differential Angular rotation and Axial load at Tie Rod computed by CAEPIPE for Operating Load Case 1 for Coupling modelled between Nodes 20 and 30 for both Temperature Increase and Temperature Decrease are less than the respective Allowable Linear Movement (0.13”), Angular Deflection (1.08 deg) and Maximum Permissible End Load (34470 lb) provided in the Catalog thereby meeting the criteria.